

QTY	CONNECTION	SIZE	SHEETS
1	FUEL INLET	3/4-14 NPSM	2,5
1	EXCESS FUEL RETURN	1 3/16-12 THD	2,5
1	EXHAUST	DETAIL	4,6,7
2	FUMES DISPOSAL HOSE	ø57.2 [ø2.25] OD	4,5
1	OIL DRAIN	1 3/16-12 THD	2,5
1	RADIATOR DRAIN	1/2-14 NPT	2,3,4

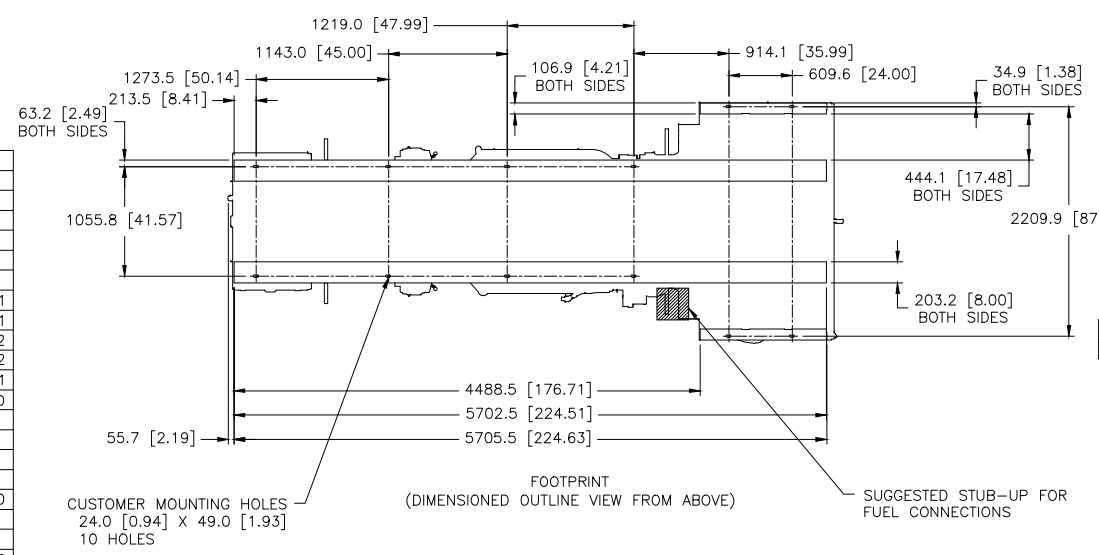
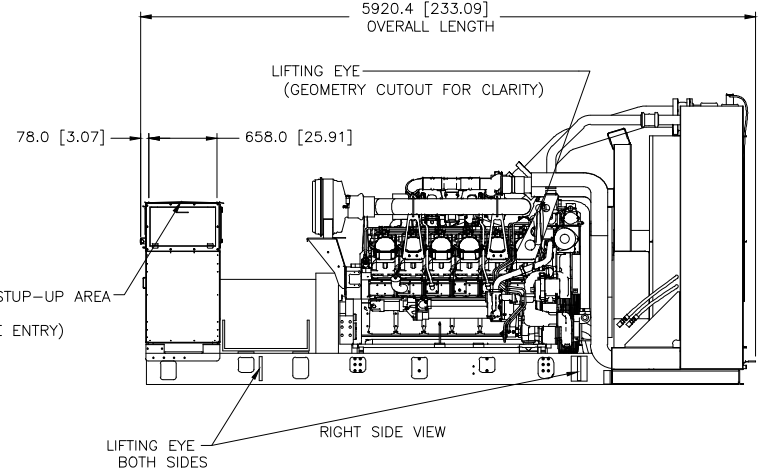
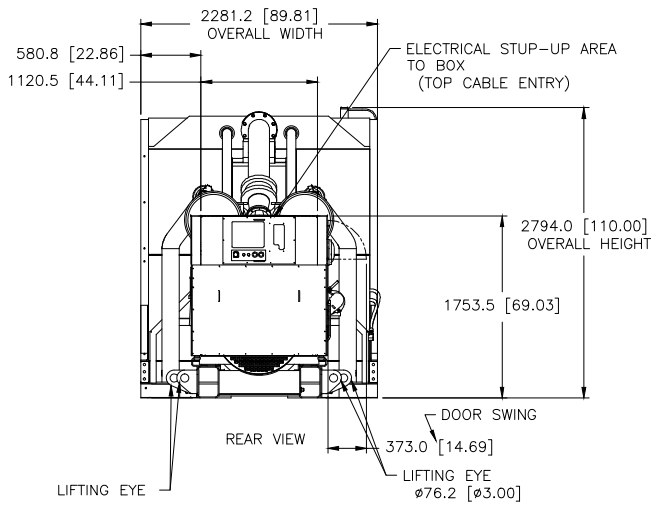

MODEL	TYPE	PRICING AR	MANDATORY ATT
3512C	-	LF-2923 CHG 04 LF-2924 CHG 03	LF-2844 CHG 02
			LF-2838 CHG 01
			LF-2975 CHG 00
			LF-2138 CHG 01
			LF-2830 CHG 00
			LF-2848 CHG 01
			516-7990 CHG 01
			491-5899 CHG 01
			491-5896 CHG 02
			491-5856 CHG 02
			375-2296 CHG 01
			447-1538 CHG 00
			LF-1344 CHG 00
			LF-2712 CHG 00
			LF-2694 CHG 01
			LF-1318 CHG 02
			325-6244 CHG 00
			LF-1865 CHG 00
			LF-1870 CHG 02
			283-2549 CHG 00
			473-4535 CHG 00
			367-5169 CHG 00
			LF-1319 CHG 01
LF-1349 CHG 00			

PACKAGE LIFTED IN 3 PLACES WITH RADIATOR INSTALLED
PACKAGE SHOWN WITH MORE DETAIL ON FOLLOWING SHEETS

1E238E810001
E2733 DRAWING - AUTOCAD
E2733 BRAND MARKINGS
E001240 NON-IDENTICAL
E001241 INTERPRETATION
E100011 IN PR & TOI
1
REV A
DATE 11/21/00
BY J.W. SWIFT
APP IN P. MOUNT JOY
IMP 1 1/8 1 1/2 1 1/4
RECORDS X
MAY 19 2001
CATERPILLAR INC.
CATERPILLAR