

FRONT VIEW

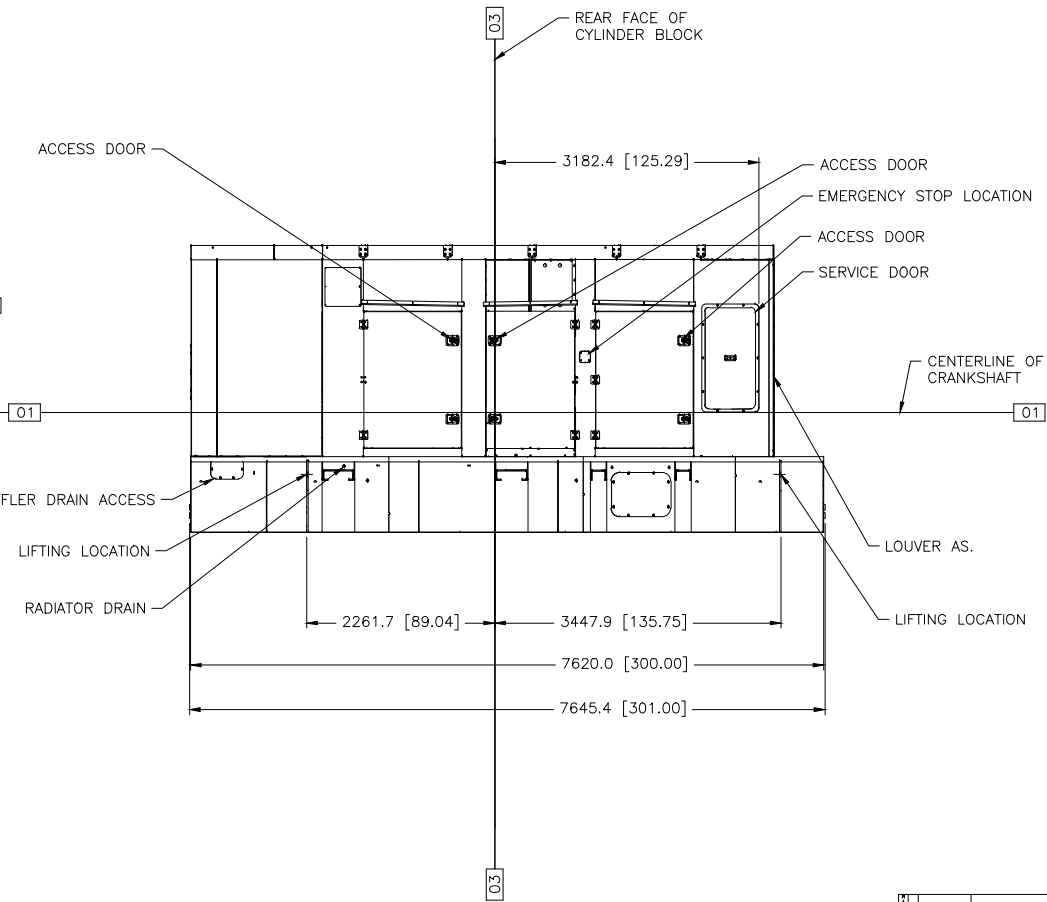

LEFT SIDE VIEW

1-2733 DRAWING-AUTOCAD	
1	FILED IN IN/20
DATE	01/15/20
BY	J. THURMAN
CHK	G. THURMAN
APP	N.P. MOUNJOY
REV	
01	01 SMARTS
<p>CATERPILLAR INC. 11500 North Central Expressway Peoria, IL 61654-0001 USA (618) 353-7000 FAX (618) 353-7100 WWW.CATERPILLAR.COM</p>	
LS-1222 V12 ENCLOSURE W/2000 GAL FUEL BASE SHOWN 436-1390	

LS-1222 V12 ENCLOSURE W/2000 GAL FUEL BASE SHOWN