

QTY	ENGINE CONNECTIONS	SIZE	SHEET
1	COOLANT DRAIN	ø19.1 [0.75] ID	2
1	EXHAUST	ø203.2 [ø8.00] OD	2
1	OIL DRAIN	ø15.9 [0.63] ID	2

QTY	POSSIBLE TANK CONNECTIONS	SIZE	SHEET
1	BASIN TANK EMERGENCY VENT	5" NPT THD	3
2	CUSTOMER CONNECTIONS	2" NPTF THD	3
1	FUEL FILLER	4" NPT THD	3
1	MAIN TANK EMERGENCY VENT	5" NPT THD	3
2	PORT	2"-1 1/2 NPTF	3
1	PORT	4"-8 NPTF	3
1	SPARE	2" NPT THD	3

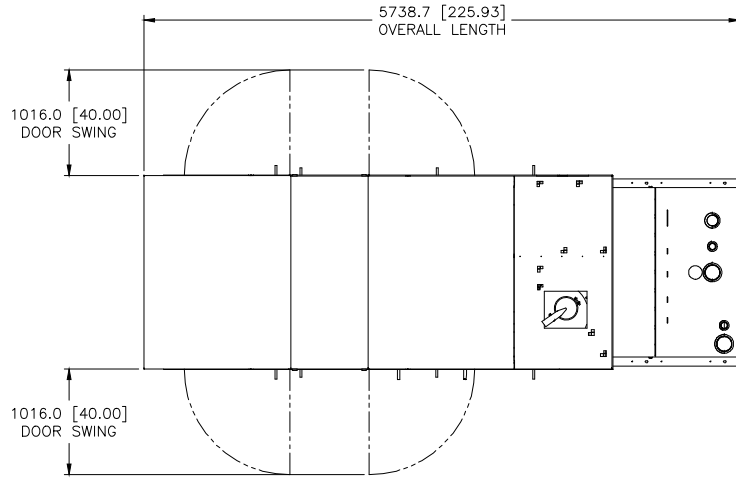

TOP VIEW

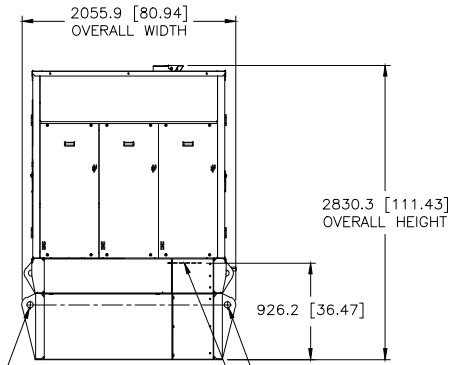

REAR VIEW

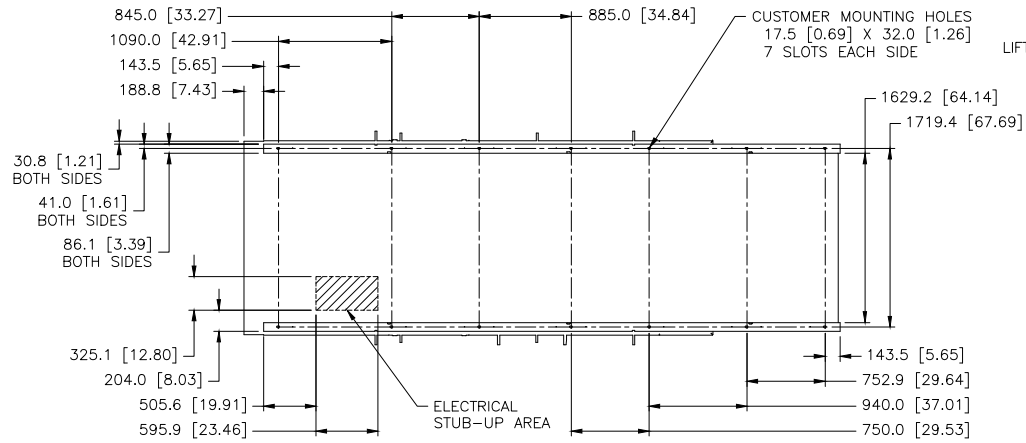

FOOTPRINT  
(DIMENSIONED OUTLINE VIEW FROM ABOVE)

MODEL	TYPE	PRICING AR	TANK	ENCLOSURE
C9	Y	LS-0249 CHG 00	LS-1846 CHG 00	LS-1838 CHG 00
				LS-1839 CHG 00
				LS-1840 CHG 00
				LS-1841 CHG 00
				LS-1869 CHG 00

NOTE: ENCLOSURE ARRANGEMENTS  
LS-1839 & LS-1841 COME WITH WINDOW

PACKAGE LIFTED IN 4 PLACES

PACKAGE SHOWN WITH MORE DETAIL ON SHEETS 2 & 3

DATE			
TIME			
BY			
CHKD			
APP'D			
DATE			
TIME			
BY			
CHKD			
APP'D			
DATE			
TIME			
BY			
CHKD			
APP'D			
DATE			
TIME			
BY			
CHKD			
APP'D			
DATE			
TIME			
BY			
CHKD			
APP'D			
DATE			
TIME			
BY			
CHKD			
APP'D			
DATE			
TIME			
BY			
CHKD			
APP'D			
DATE			
TIME			
BY			
CHKD			
APP'D			
DATE			
TIME			
BY			
CHKD			
APP'D			
DATE			
TIME			
BY			
CHKD			
APP'D			
DATE			
TIME			
BY			
CHKD			
APP'D			
DATE			
TIME			
BY			
CHKD			
APP'D			
DATE			
TIME			
BY			
CHKD			
APP'D			
DATE			
TIME			
BY			
CHKD			
APP'D			
DATE			
TIME			
BY			
CHKD			
APP'D			
DATE			
TIME			
BY			
CHKD			
APP'D			
DATE			
TIME			
BY			
CHKD			
APP'D			
DATE			
TIME			
BY			
CHKD			
APP'D			
DATE			
TIME			
BY			
CHKD			
APP'D			
DATE			
TIME			
BY			
CHKD			
APP'D			
DATE			
TIME			
BY			
CHKD			
APP'D			
DATE			
TIME			
BY			
CHKD			
APP'D			
DATE			
TIME			
BY			
CHKD			
APP'D			
DATE			
TIME			
BY			
CHKD			
APP'D			
DATE			
TIME			
BY			
CHKD			
APP'D			
DATE			
TIME			
BY			
CHKD			
APP'D			
DATE			
TIME			
BY			
CHKD			
APP'D			
DATE			
TIME			
BY			
CHKD			
APP'D			
DATE			
TIME			
BY			
CHKD			
APP'D			
DATE			
TIME			
BY			
CHKD			
APP'D			
DATE			
TIME			
BY			
CHKD			
APP'D			
DATE			
TIME			
BY			
CHKD			
APP'D			
DATE			
TIME			
BY			
CHKD			
APP'D			
DATE			
TIME			
BY			
CHKD			
APP'D			
DATE			
TIME			
BY			
CHKD			
APP'D			
DATE			
TIME			
BY			
CHKD			
APP'D			
DATE			
TIME			
BY			
CHKD			
APP'D			
DATE			
TIME			
BY			
CHKD			
APP'D			
DATE			
TIME			
BY			
CHKD			
APP'D			
DATE			
TIME			
BY			
CHKD			
APP'D			
DATE			
TIME			
BY			
CHKD			
APP'D			
DATE			
TIME			
BY			
CHKD			
APP'D			
DATE			
TIME			
BY			
CHKD			
APP'D			
DATE			
TIME			
BY			
CHKD			
APP'D			
DATE			
TIME			
BY			
CHKD			
APP'D			
DATE			
TIME			
BY			
CHKD			
APP'D			
DATE			
TIME			
BY			
CHKD			
APP'D			
DATE			
TIME			
BY			
CHKD			
APP'D			
DATE			
TIME			
BY			
CHKD			
APP'D			
DATE			
TIME			
BY			
CHKD			
APP'D			
DATE			
TIME			
BY			
CHKD			
APP'D			
DATE			
TIME			
BY			
CHKD			
APP'D			
DATE			
TIME			
BY			
CHKD			
APP'D			
DATE			
TIME			
BY			
CHKD			
APP'D			
DATE			
TIME			
BY			
CHKD			
APP'D			
DATE			
TIME			
BY			
CHKD			
APP'D			
DATE			
TIME			
BY			
CHKD			
APP'D			
DATE			
TIME			
BY			
CHKD			
APP'D			
DATE			
TIME			
BY			
CHKD			
APP'D			
DATE			
TIME			
BY			
CHKD			
APP'D			
DATE			
TIME			
BY			
CHKD			
APP'D			
DATE			
TIME			
BY			
CHKD			
APP'D			
DATE			
TIME			
BY			
CHKD			
APP'D			
DATE			
TIME			
BY			
CHKD			
APP'D			
DATE			
TIME			
BY			
CHKD			
APP'D			
DATE			
TIME			
BY			
CHKD			
APP'D			
DATE			
TIME			
BY			
CHKD			
APP'D			
DATE			
TIME			
BY			
CHKD			
APP'D			
DATE			
TIME			
BY			
CHKD			
APP'D			
DATE			
TIME			
BY			
CHKD			
APP'D			
DATE			
TIME			
BY			
CHKD			
APP'D			
DATE			
TIME			
BY			
CHKD			
APP'D			
DATE			
TIME			
BY			
CHKD			
APP'D			