

QTY	ENGINE CONNECTIONS	SIZE	SHEET
1	COOLANT DRAIN	ø19.1 [0.75] ID	2
1	EXHAUST	ø203.0 [ø7.99] OD	2
1	OIL DRAIN	ø19.1 [0.75] ID	2

QTY	POSSIBLE TANK CONNECTIONS	SIZE	SHEET
1	BASIN TANK EMERGENCY VENT	5" NPTF THD	2
2	CUSTOMER CONNECTIONS	2" NPTF THD	2
1	FUEL FILLER	4" NPTF THD	2
1	MAIN TANK EMERGENCY VENT	5" NPTF THD	2
1	SPARE	2" NPT	2

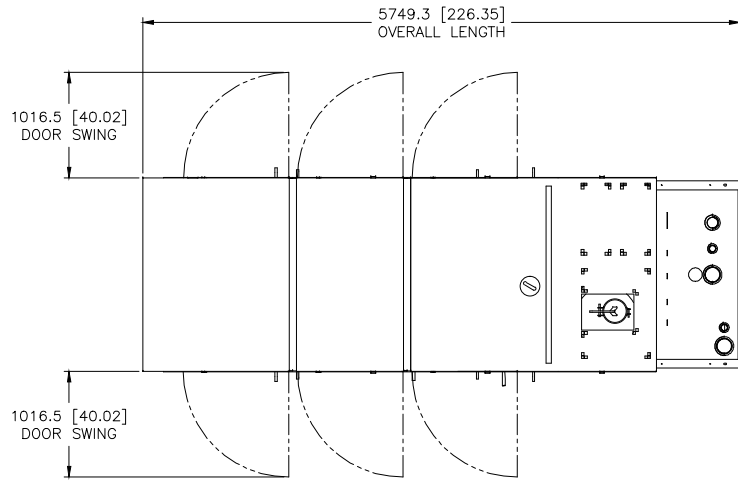

TOP VIEW

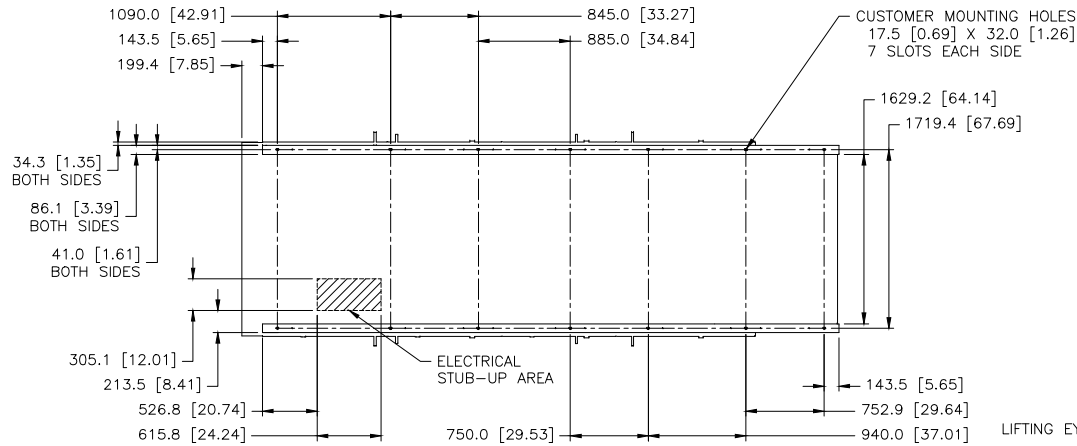

FOOTPRINT
(DIMENSIONED OUTLINE VIEW FROM ABOVE)

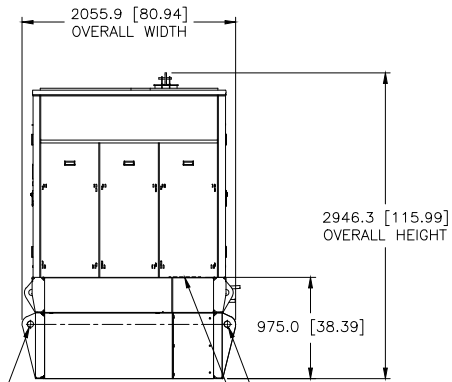

REAR VIEW

LIFTING EYE
ø60.0 [ø2.36]
2 PLACES EACH SIDE

ELECTRICAL STUB-UP AREA

PACKAGE LIFTED IN 4 PLACES
PACKAGE SHOWN WITH MORE DETAIL ON SHEET 2

MODEL	TYPE	PRICING AR	ENCLOSURE	FUEL TANK
C13	Y	LS-1503 CHG 00	LS-1511 CHG 00	LS-1524 CHG 00
			LS-1513 CHG 00	
			LS-1519 CHG 00	
			LS-1512 CHG 00	
			LS-1514 CHG 00	
			LS-1520 CHG 00	
		LS-1543 CHG 00		

REVISIONS

NO.	DATE	DESCRIPTION
1		
2		
3		
4		
5		
6		
7		
8		
9		
10		
11		
12		
13		
14		
15		
16		
17		
18		
19		
20		
21		
22		
23		
24		
25		
26		
27		
28		
29		
30		
31		
32		
33		
34		
35		
36		
37		
38		
39		
40		
41		
42		
43		
44		
45		
46		
47		
48		
49		
50		

1E2966H IDENT
 1E2733 DRAWING-AUTOCAD
 1E0198H BRAND MARKINGS
 1E0018H BRAND IDENTICALS
 1E0012H INTERPRETATION
 1E0011H INSTR & TOOL
 1E0000H IDENT

DESIGNED BY: M. J. SWIFT
 CHECKED BY: J. SWIFT
 DRAWN BY: M. JOY
 DATE: 1991-11-18
 SHEET: 1 OF 2
 RECORDS: X

SHEET 1 OF 18
 5 MAY 1992
 509-6533

CATERPILLAR INC.
 14000 E. CENTRAL EXPRESSWAY
 IRVING, TEXAS 75014-1099
 C13 SA L1 ENC 10000 TANK
 509-6533