



Picture shown may not reflect actual configuration

Weather Protective and Sound Attenuated Enclosures

DG100-2, DG125-2, and DG150-2

Features

Highly Corrosion Resistant construction

- Stainless steel flush fitting latches and hinges tested and proven to withstand extreme conditions of corrosion
- Zinc plated or stainless steel fastener

Excellent Access

- Radiator fill access
- Lube oil and coolant drains piped to the exterior of the enclosure base
- Large cable entry area for installation ease
- Removable, vertically hinged double doors on both sides with rubber external snap-in-place door securement when fully opened
- Removable, vertically hinged rear door for control panel access with solid bar door stay to hold door in place when open
- Removable front panel

Security and Safety

- Lockable access doors which give full access to control panel and breaker
- Cooling fan and battery charging alternator fully guarded
- Oil fill, and battery can only be reached via lockable access
- Stub-up area is rodent proof

Transportability

- These enclosures are of extremely rugged construction to withstand outdoor exposure and rough handling common on many construction sites. The sound deadening material is of a self-extinguishing design
- This range of enclosures are designed on modular principles with many interchangeable components permitting on site repair

Options

- Weather Protective – constructed with 16 gauge steel
- Sound Attenuated – constructed with 16 gauge steel; weather protective with critical silencer and lined with sound deadening material – silencer mounted in separate upward discharging radiator hood
- Caterpillar Yellow or white paint
- Externally mounted emergency stop button
- IBC certification for 180 mph wind loading

Enclosure Sound Pressure Levels (SPL) at 100%

Sound Attenuated Enclosure		Cooling Air Flow Rate		SPL @7m (23ft)
Model	Standby eKW	m ³ /s	cfm	dBA
DG100-2	100	3.1	6569	74
DG125-2	125	3.7	7840	72
DG150-2	150	5.5	11654	75

Weather Protective Enclosure		Cooling Air Flow Rate		SPL @7m (23ft)
Model	Standby eKW	m ³ /s	cfm	dBA
DG100-2	100	4.4	9323	83
DG125-2	125	3.9	8264	79
DG150-2	150	5.3	11230	88

Component Weights to Calculate Package Weight

Model	Standby eKW	Sound Attenuated		Weather Protective	
		kg	lb	kg	lb
DG100-2	100	347	765	212	467
DG125-2	125	347	765	212	467
DG150-2	150	360	794	212	467

Enclosure Dimensions

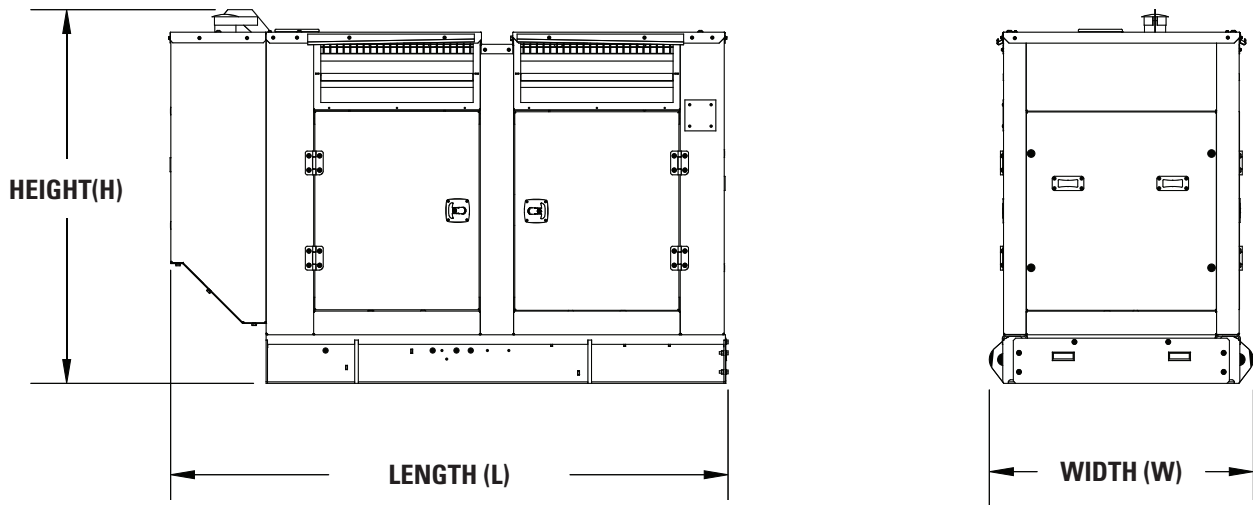

Image represents SA enclosures

Model	Generator Set Rating ekW	Enclosure	Width 'W'		Length 'L'		Height 'H'	
			mm	in	mm	in	mm	in
DG100-2	100	Sound Attenuated	1110	43.7	3659	144.1	1853	73.0
DG125-2	125						1866	73.5
DG150-2	150						1875	73.8
DG100-2	100	Weather Protective	1110	43.7	3232	127.2	1866	73.5
DG125-2	125							
DG150-2	150							

LET'S DO THE WORK.™